

TECH DISTRIBUTION

DISTRIBUTEUR À POUSSOIR
ET À GALET

SÉRIE
BV/BR/BL

DISTRIBUTEUR À POUSSOIR ET À GALET

SÉRIE
BV/BR/BL

M5

BV 311 202

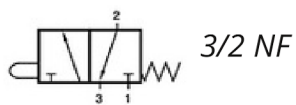

M5

BR 311 202

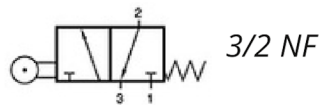

M5

BL 311 202

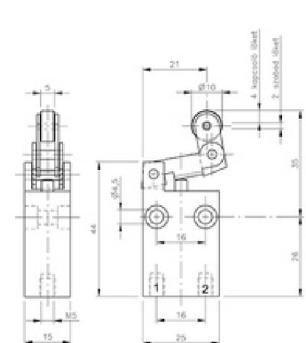
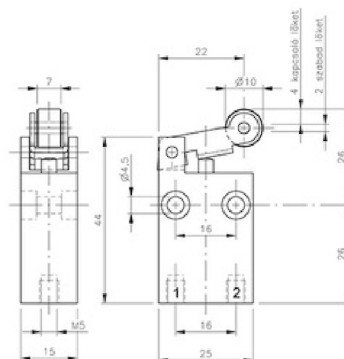
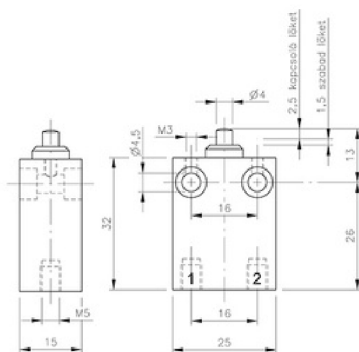
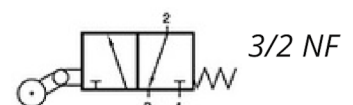

Référence	Orifice	Débit	Pression	puissance de déclenchement	Poids
BV 311 202	M5	115 l/min	-0,9 - 10 bars	14 N	0,033 kg
BR 311 202	M5	115 l/min	-0,9 - 10 bars	9 N	0,041 kg
BL 311 202	M5	115 l/min	-0,9 - 10 bars	9 N	0,044 kg

DISTRIBUTEUR À POUSSOIR ET À GALET

SÉRIE BV/BR/BL

⊕ \square Ø4

BV 311 243

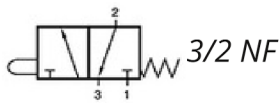

⊕ \square Ø4

BR 311 243

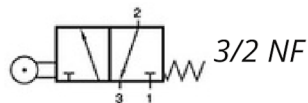

⊕ \square Ø4

BL 311 243

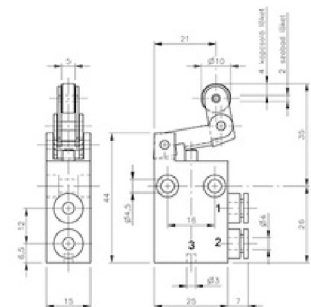
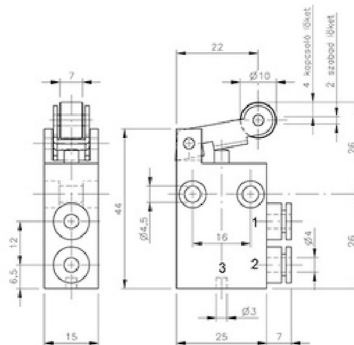
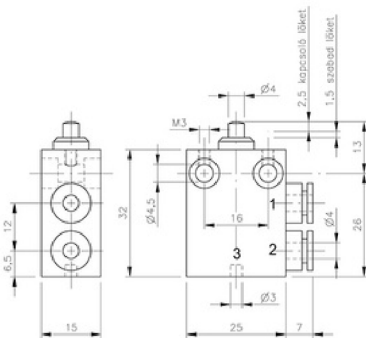
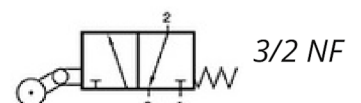

Référence	Orifice	Débit	Pression	puissance de déclenchement	Poids
BV 311 243	Ø4	115 l/min	-0,9 - 10 bars	14 N	0,033 kg
BR 311 243	Ø4	115 l/min	-0,9 - 10 bars	9 N	0,041 kg
BL 311 243	Ø4	115 l/min	-0,9 - 10 bars	9 N	0,044 kg

DISTRIBUTEUR À POUSSOIR ET À GALET

SÉRIE
BV/BR/BL



G1/8"

BV 311 301

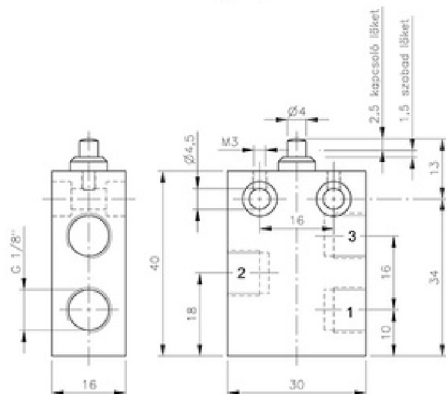
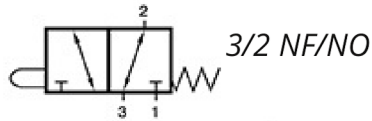

G1/4"

BR 311 301

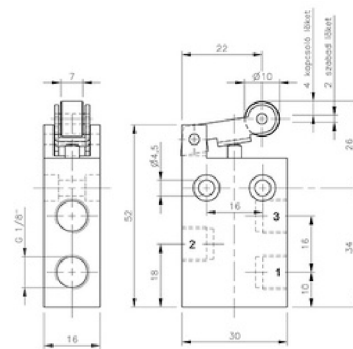
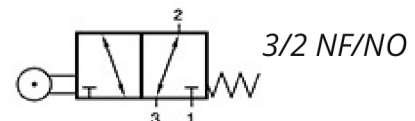

Référence	Orifice	Débit	Pression	puissance de déclenchement	Poids
BR 311 501	G1/8"	650 l/min	1 - 10 bars	3,5 N	0,19 kg
BR 311 701	G1/4"	1250 l/min	1 - 10 bars	3,5 N	0,20 kg

DISTRIBUTEUR À POUSSOIR ET À GALET

SÉRIE
BV/BR/BL

G1/8"

BV 511 301

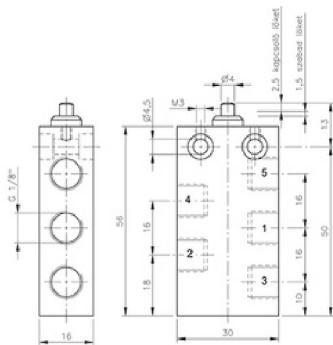
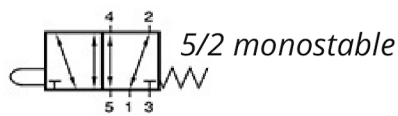

G1/8"

BR 511 301

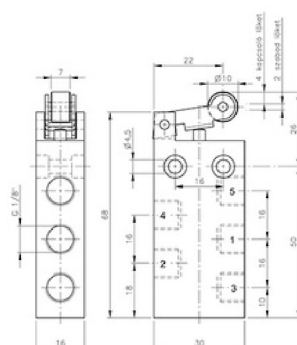
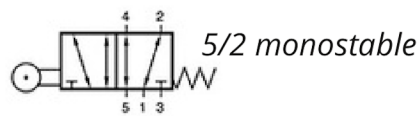

G1/8"

BL 511 301

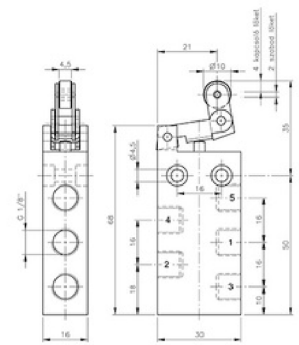
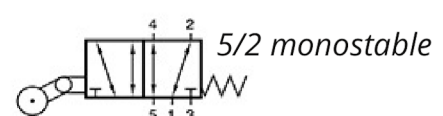

Référence	Orifice	Débit	Pression	puissance de déclenchement	Poids
BV 511 301	G 1/8"	280 l/min	-0,9 - 10 bars	14 N	0,065 kg
BR 511 301	G 1/8"	280 l/min	-0,9 - 10 bars	10 N	0,077 kg
BL 511 301	G 1/8"	280 l/min	-0,9 - 10 bars	10 N	0,079 kg

DISTRIBUTEUR À POUSSOIR ET À GALET

SÉRIE
BV/BR/BL



G1/8"

G1/4"

BR 511 501

BR 511 701

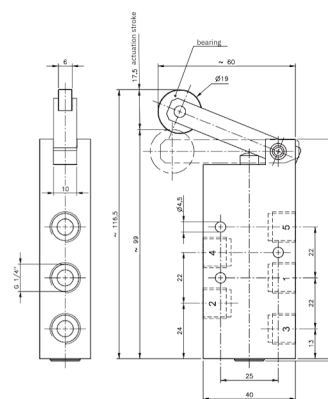
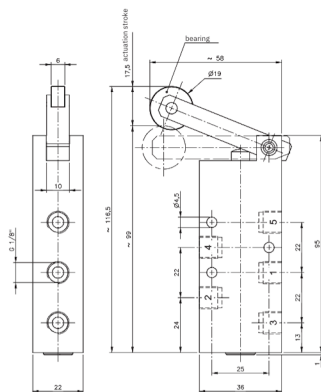
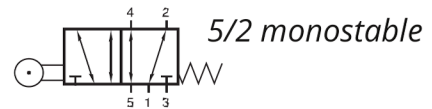
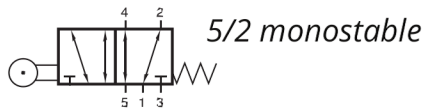

Référence	Orifice	Débit	Pression	puissance de déclenchement	Poids
BR 511 501	G1/8"	650 l/min	1 - 10 bars	3,5 N	0,23 kg
BR 511 701	G1/4"	1250 l/min	1 - 10 bars	3,5 N	0,25 kg