

DATECH



VANNES POUSSER-TIRER

SÉRIE
BH

VANNES POUSSER-TIRER

BH



G 1/8"

BH 311 401

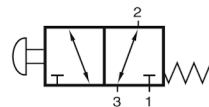

3/2 NF/NO

BH 320 401

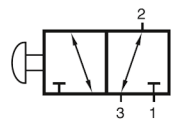

3/2 bistable

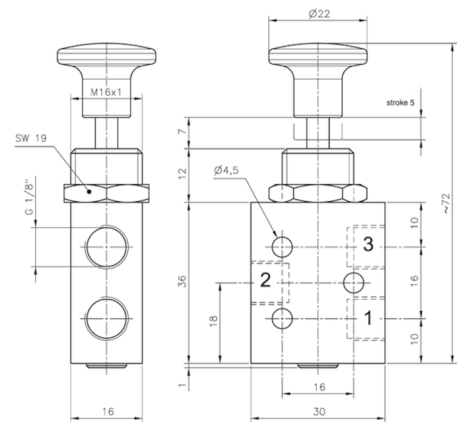

G 1/4"

BH 311 701

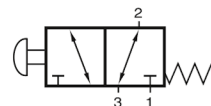

3/2 NF/NO

BH 320 701

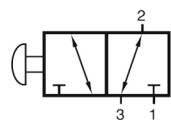

3/2 bistable

Référence	Orifice	Débit	Pression	puissance de déclenchement	Poids
BH 311 401	G 1/8"	450 l/min	1 - 10 bars	11 N	0,064 kg
BH 320 401	G 1/8"	450 l/min	1 - 10 bars	12 N	0,064 kg
BH 311 701	G 1/4"	1250 l/min	-0,9 - 10 bars	17 N	0,140 kg
BH 320 701	G 1/4"	1250 l/min	-0,9 - 10 bars	18 N	0,140 kg

VANNES POUSSER-TIRER

BH



G 1/8"

BH 511 401



BH 520 401

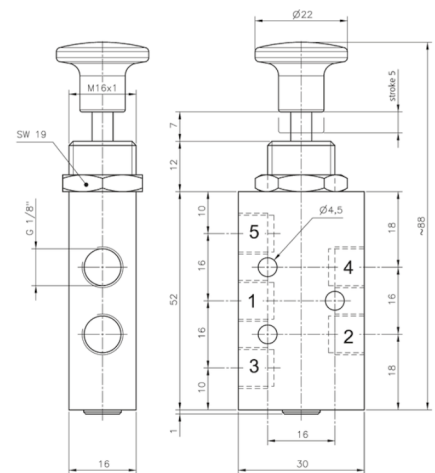
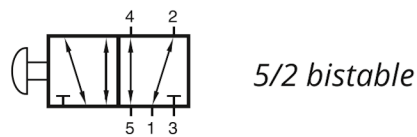

G 1/4"

BH 511 701

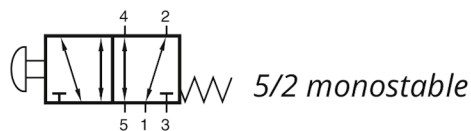

BH 520 701

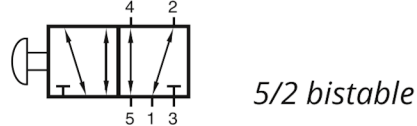

Référence	Orifice	Débit	Pression	puissance de déclenchement	Poids
BH 511 401	G 1/8"	450 l/min	1 - 10 bars	11 N	0,080 kg
BH 520 401	G 1/8"	450 l/min	1 - 10 bars	12 N	0,080 kg
BH 511 701	G 1/4"	1250 l/min	-0,9 - 10 bars	17 N	0,180 kg
BH 520 701	G 1/4"	1250 l/min	-0,9 - 10 bars	18 N	0,180 kg

VANNES POUSSER-TIRER

BHP

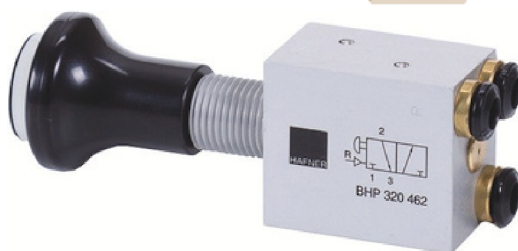

ø 4 mm

BHP 320 442

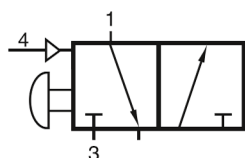

3/2 bistable

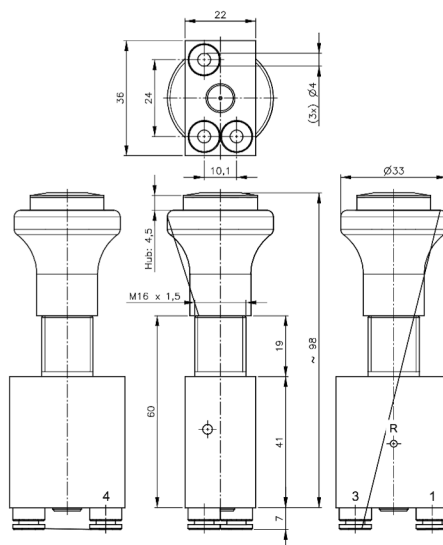

ø 6 mm

BHP 320 462

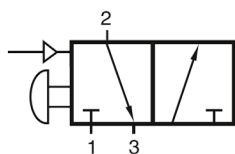

3/2 bistable

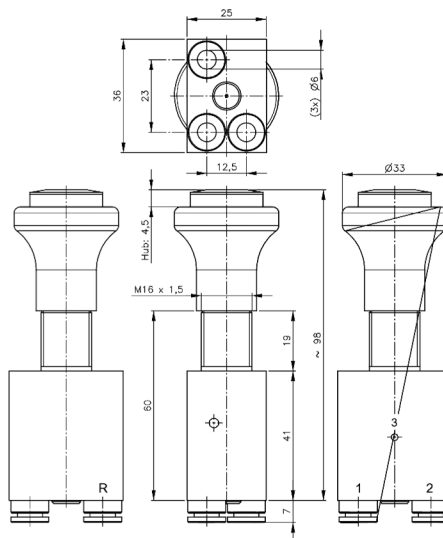

Référence	Orifice	Débit	Pression	Poids
BHP 320 442	ø 4 mm	300 l/min	1 - 16 bars	0,13 kg
BHP 320 462	ø 6 mm	300 l/min	1 - 16 bars	0,13 kg

VANNES POUSSER-TIRER

BHP

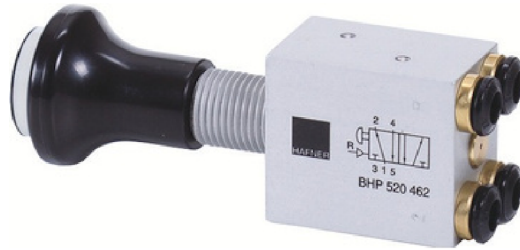

∅ 4 mm

BHP 520 442

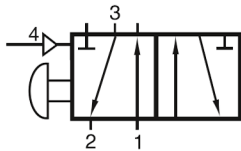

5/2 bistable

∅ 6 mm

BHP 520 462

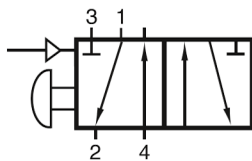

5/2 bistable

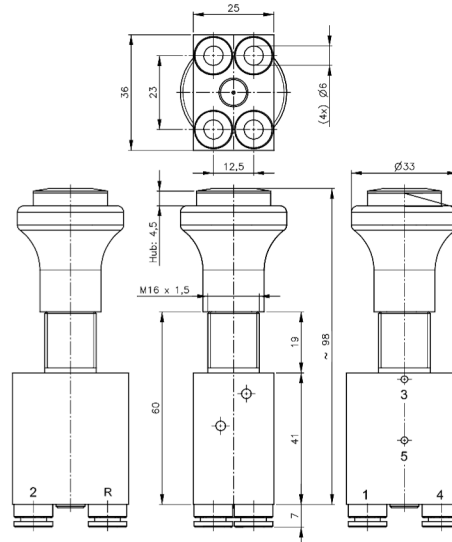
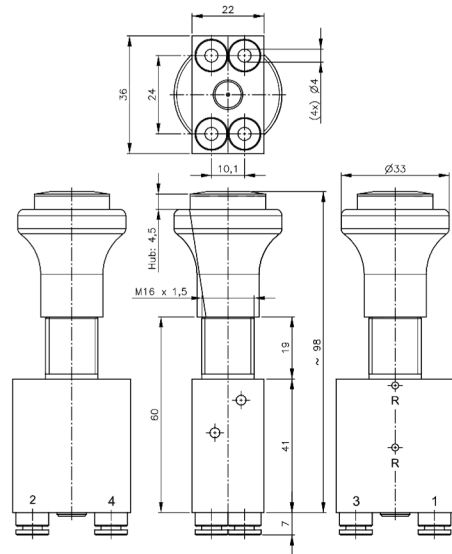

Référence	Orifice	Débit	Pression	Poids
BHP 520 442	∅ 4 mm	300 l/min	1 - 16 bars	0,13 kg
BHP 520 462	∅ 6 mm	300 l/min	1 - 16 bars	0,13 kg