

Série

F

FICHE TECHNIQUE

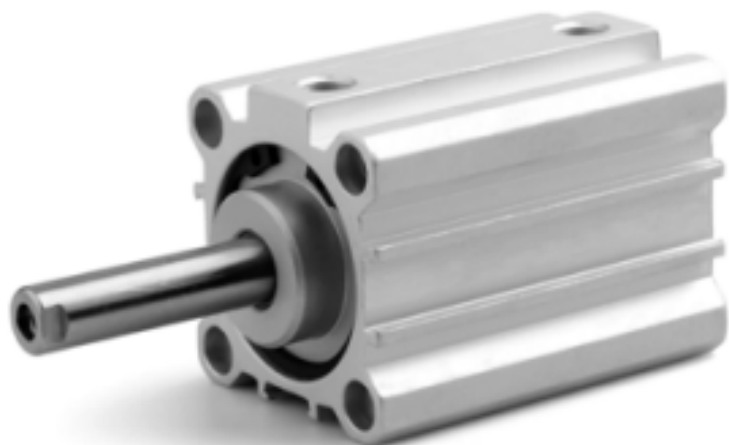

Vérin (faible course)

DATECH
MANUFACTURE PNEUMATIQUE

Alésage	Action	À une température ambiante de 20°C avec un coefficient de sécurité de 10%									
		1 bar	2 bar	3 bar	4 bar	5 bar	6 bar	7 bar	8 bar	9 bar	10 bar
8	Poussée	0,45	0,90	1,36	1,81	2,26	2,71	3,17	3,62	4,07	4,52
	Traction	1,00	1,00	1,00	1,00	1,00	1,00	1,00	1,00	1,00	1,00
10	Poussée	0,71	1,41	2,12	2,83	3,53	4,24	4,95	5,65	6,36	7,07
	Traction	1,00	1,00	1,00	1,00	1,00	1,00	1,00	1,00	1,00	1,00
12	Poussée	1,017	2,035	3,053	4,071	5,089	6,107	7,124	8,142	9,160	10,178
	Traction	0,763	1,526	2,290	3,053	3,816	4,58	5,343	6,107	6,870	7,633
16	Poussée	1,809	3,619	5,428	7,238	9,047	10,587	12,666	14,476	16,285	18,095
	Traction	1,555	3,110	4,665	6,220	7,775	9,330	10,885	12,440	13,995	15,550
20	Poussée	2,827	5,654	8,482	11,309	14,136	16,964	19,791	22,618	25,446	28,273
	Traction	2,374	4,749	7,124	9,499	11,874	14,249	16,624	18,999	21,374	23,749
25	Poussée	4,417	8,835	13,253	17,670	22,088	26,506	30,924	35,341	39,759	44,177
	Traction	3,710	7,421	11,131	14,842	18,552	22,263	25,973	29,684	33,394	37,105
32	Poussée	7,238	14,476	21,714	28,952	36,190	43,428	50,666	57,904	65,142	72,380
	Traction	6,220	12,440	18,660	24,880	31,100	37,321	43,541	49,761	55,981	62,201
40	Poussée	11,309	22,618	33,928	45,237	56,547	67,856	79,165	90,475	101,78	113,09
	Traction	9,499	18,999	28,499	37,999	47,499	56,999	66,499	75,999	85,499	94,998
50	Poussée	17,670	35,341	53,012	70,683	88,354	106,02	123,69	141,36	159,03	176,70
	Traction	14,843	29,687	44,530	59,374	74,217	89,061	103,90	118,74	133,59	148,43
63	Poussée	28,054	56,108	84,163	112,21	140,27	168,32	196,38	224,43	252,49	280,54
	Traction	25,227	50,454	75,681	100,90	126,13	151,36	176,58	201,81	227,04	252,27
80	Poussée	45,237	90,475	135,71	180,95	226,18	271,42	316,66	361,90	407,13	452,37
	Traction	40,819	81,639	122,45	163,27	204,09	244,91	285,73	326,55	367,37	408,19
100	Poussée	70,683	141,36	212,05	282,73	353,41	424,10	494,78	565,47	636,15	706,83
	Traction	66,266	132,53	198,79	265,06	331,33	397,59	463,86	530,12	596,39	662,66
125	Poussée	110,44	220,88	331,33	441,77	552,21	662,66	773,10	883,54	993,99	1104,4
	Traction	103,20	206,41	309,61	412,82	516,02	619,23	722,43	825,64	928,84	1032,0
160	Poussée	180,95	361,90	542,85	723,80	904,75	1085,7	1266,6	1447,6	1628,5	1809,5
	Traction	169,64	339,28	508,92	678,56	848,20	1017,8	1187,4	1357,1	1526,7	1696,4
200	Poussée	282,73	565,47	848,20	1130,9	1413,6	1696,4	1979,1	2261,8	2544,6	2827,3
	Traction	271,42	542,85	814,27	1085,7	1357,1	1628,5	1899,9	2171,4	2442,8	2714,2
250	Poussée	441,82	883,63	1325,4	1767,2	2209,1	2650,9	3092,7	3535,5	3976,3	4418,2
	Traction	424,14	848,29	1272,4	1696,5	2120,7	2544,8	2969,1	3393,1	3817,3	4241,4
320	Poussée	1447,7	2171,6	2171,6	2895,5	3619,3	4581,9	5067,1	5791,1	6514,9	7238,7
	Traction	1391,6	2087,4	2087,4	2783,2	3479,1	4404,3	4870,7	5566,5	6262,3	6958,2

Alésage	Action	À une température ambiante de 20°C									
		1 bar	2 bar	3 bar	4 bar	5 bar	6 bar	7 bar	8 bar	9 bar	10 bar
12	Poussée	0,0023	0,0034	0,0045	0,0057	0,0068	0,0079	0,0090	0,0102	0,0113	0,0124
	Traction	0,0016	0,0025	0,0033	0,0042	0,0050	0,0059	0,0067	0,0076	0,0084	0,0093
16	Poussée	0,0040	0,0060	0,0080	0,0100	0,0121	0,0141	0,0161	0,0181	0,0202	0,0221
	Traction	0,0034	0,0051	0,0069	0,0086	0,0103	0,0121	0,0138	0,0155	0,0173	0,0190
20	Poussée	0,0063	0,0094	0,0126	0,0157	0,0188	0,0220	0,0251	0,0283	0,0314	0,0346
	Traction	0,0053	0,0079	0,0105	0,0132	0,0158	0,0185	0,0211	0,0237	0,0264	0,0290
25	Poussée	0,0098	0,0147	0,0196	0,0245	0,0295	0,0344	0,0393	0,0442	0,0491	0,0540
	Traction	0,0082	0,0124	0,0165	0,0206	0,0247	0,0288	0,0330	0,0371	0,0412	0,0453
32	Poussée	0,0160	0,0241	0,0321	0,0402	0,0482	0,0562	0,0643	0,0723	0,0804	0,0884
	Traction	0,0138	0,0207	0,0276	0,0345	0,0414	0,0483	0,0552	0,0622	0,0691	0,0760
40	Poussée	0,0251	0,0376	0,0502	0,0628	0,0753	0,0879	0,1005	0,1130	0,1256	0,1382
	Traction	0,0211	0,0316	0,0422	0,0527	0,0633	0,0738	0,0844	0,0949	0,1055	0,1161
50	Poussée	0,0392	0,0589	0,0785	0,0981	0,1178	0,1374	0,1570	0,1767	0,1963	0,2159
	Traction	0,0329	0,0494	0,0659	0,0824	0,0989	0,1154	0,1319	0,1484	0,1649	0,1814
63	Poussée	0,0623	0,0935	0,1246	0,1558	0,1870	0,2182	0,2493	0,2805	0,3117	0,3428
	Traction	0,0560	0,0840	0,1121	0,1401	0,1681	0,1962	0,2242	0,2522	0,2803	0,3083
80	Poussée	0,1005	0,1507	0,2010	0,2513	0,3015	0,3518	0,4021	0,4523	0,5026	0,5529
	Traction	0,0907	0,1360	0,1814	0,2267	0,2721	0,3174	0,3628	0,4081	0,4535	0,4989
100	Poussée	0,1570	0,2356	0,3141	0,3926	0,4712	0,5497	0,6282	0,7068	0,7853	0,8639
	Traction	0,1472	0,2208	0,2945	0,3681	0,4417	0,5154	0,5890	0,6626	0,7362	0,8099
125	Poussée	0,2454	0,3681	0,4908	0,6135	0,7362	0,8590	0,9817	1,1044	1,2271	1,3498
	Traction	0,2293	0,3440	0,4586	0,5733	0,6880	0,8027	0,9173	1,0320	1,1467	1,2613
160	Poussée	0,4021	0,6031	0,8042	1,0052	1,2063	1,4073	1,6084	1,8095	2,0105	2,2116
	Traction	0,3769	0,5654	0,7539	0,9424	1,1309	1,3194	1,5079	1,6964	1,8848	2,0733
200	Poussée	0,6282	0,9424	1,2565	1,5707	1,8848	2,1990	2,5131	2,8273	3,1415	3,4556
	Traction	0,6031	0,9047	1,2063	1,5079	1,8095	2,1110	2,4126	2,7142	3,0158	3,3174
250	Poussée	0,9817	1,4726	1,9635	2,4544	2,9452	3,4361	3,9270	4,4179	4,9087	5,3996
	Traction	0,9425	1,4137	1,8850	2,3562	2,8274	3,2987	3,7699	4,2412	4,7124	5,1836
320	Poussée	1,6085	2,4127	3,2170	4,0212	4,8255	5,6297	6,4340	7,2382	8,0425	8,8467
	Traction	1,5462	2,3192	3,0923	3,8654	4,6385	5,4115	6,1846	6,9577	7,7308	8,5038

Famille de produit	Vérin compact (faible course)		
Série	F		

Caractéristiques Techniques

Pression de service	1 / 10 bar (double effet) 2 / 10 bar (simple effet)
Températures de fonctionnement	0 / +80°C (-20°C avec air sec) 0 / +150 ° C (avec joints haute température)
Versions	Double effet - Simple effet - Double Tige - Anti-rotation
Alésages	Ø 12 - 16 - 20 - 25 - 32 - 40 - 50 - 63 - 80 - 100
Courses	Toute course standard.
Fluide	Air comprimé filtré, non lubrifié

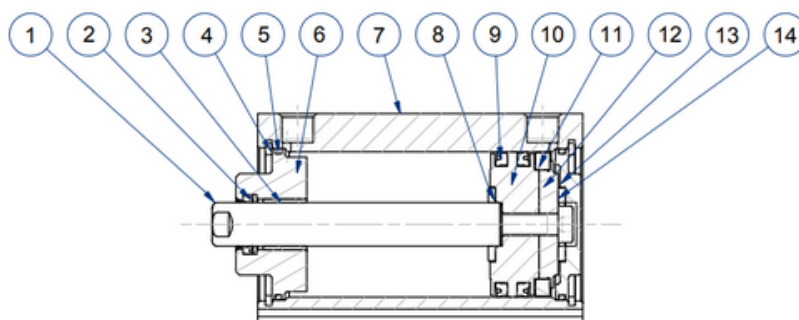

①	Tige	Acier inox 303
②⑨	Joint	Polyuréthane
③	Bague	Acier + PTFE
④	Retour ressort	Acier
⑤	Joint torique	NBR
⑥⑬	Fonderie	Ø 12÷25 laiton Ø 32÷100 aluminium anodisé
⑦	Tube	aluminium anodisé
⑧⑭	Amortissement	Vulkollan
⑩⑫	Piston	Aluminium
⑪	Anneaux magnétique	aimant en caoutchouc
	Ressort	Acier

Famille de produit	Vérin compact (faible course)		
Série	F	Version	FISR

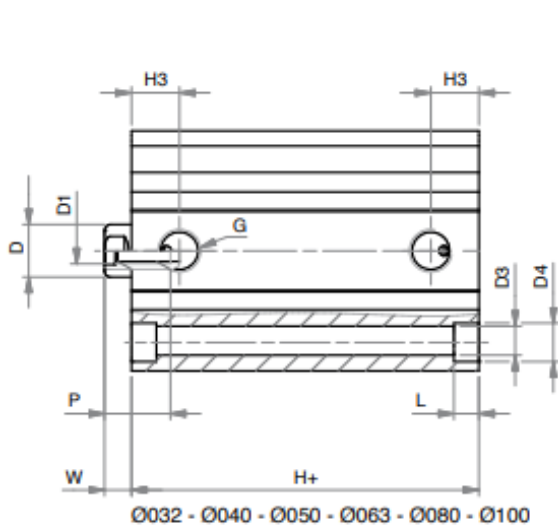
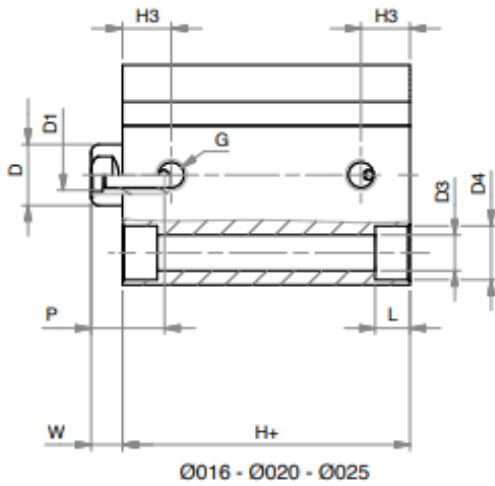
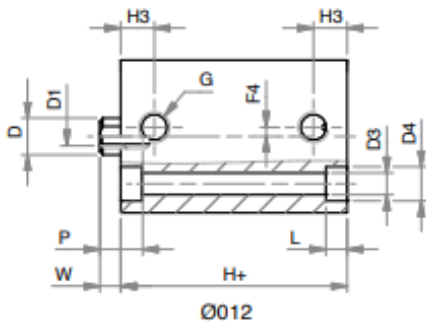
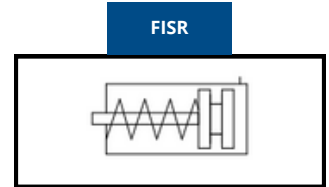

Famille de produit	Vérin compact (faible course)		
Série	F	Version	FISR

Dimensions

ø	012	016	020	025	032	040	050	063	080	100
A	25	34	40	44,5	51	58	70	89	105	131
B	25	30	36	40	46	55	65	80	100	124
ø D	6	8	10	10	12	12	16	16	20	25
D1	M3	M4	M5	M5	M6	M6	M8	M8	M10	M12
ø D3	3,7	**	5,8	5,8	5,8	5,8	6,8	9	9	11
ø D4	5,6	**	9	9	9	9	11	14	14	17,2
E	-	19	22	24,5	27	30,5	37,5	46	55	69
G	M5	M5	M5	G1/8	G1/8	G1/8	G1/8	G1/8	G1/4	G1/4
H+	17***	27	27	28,5	29,5*	29,5*	34,5*	37*	46*	56*
H3	5,5	8	8	10,5	11,5	11	11,5	11	14	16
I1	15,5	-	-	-	36	42	50	62	82	103
I2	-	18	20	26	32	42	50	62	82	103
I3	-	12	15	15,5	-	-	-	-	-	-
I5	-	20	25,5	28	34	40	50	60	77	94
I6	-	10	12,7	14	-	-	-	-	-	-
K	5	6	8	8	10	10	13	13	17	22
L	3,5	4,6	5,7	5,7	5,7	5,7	6,8	8,8	9	11
L1	-	3,5	5,7	5,7	-	-	-	-	-	-
N	-	32	38,5	42	48	55	65	80	100	124
P	7	11	12	12	15	15	17	17	17	22
W	3,5	4,5	5	5,5	6	6	7,5	7	8	10

Famille de produit	Vérin compact (faible course)		
Série	F	Version	FISR...M

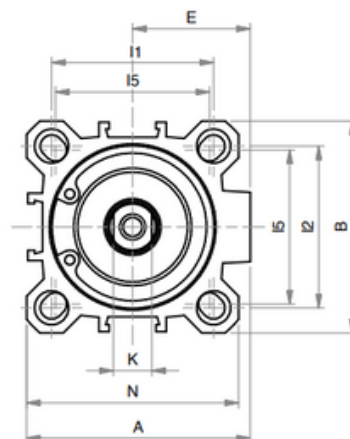
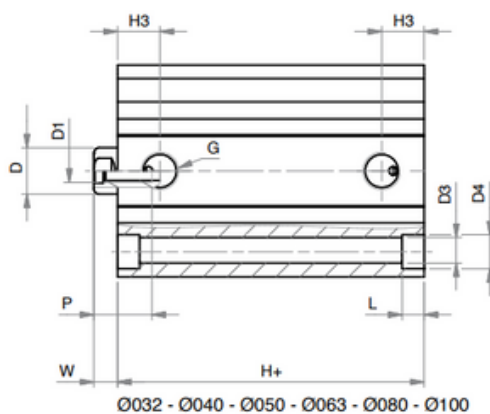
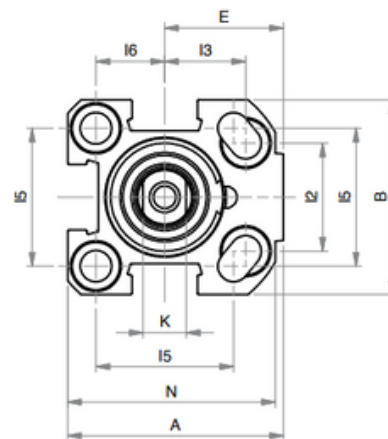
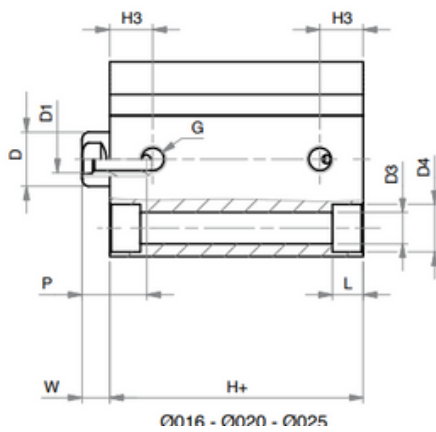
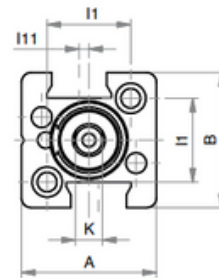
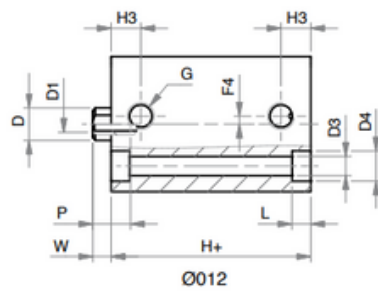
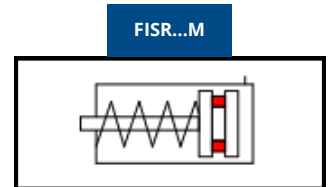

Famille de produit	Vérin compact (faible course)		
Série	F	Version	FISR...M

Dimensions

ø	012	016	020	025	032	040	050	063	080	100
A	25	34	40	44,5	51	58	70	89	105	131
B	25	30	36	40	46	55	65	80	100	124
ø D	6	8	10	10	12	12	16	16	20	25
D1	M3	M4	M5	M5	M6	M6	M8	M8	M10	M12
ø D3	3,7	**	5,8	5,8	5,8	5,8	6,8	9	9	11
ø D4	5,6	**	9	9	9	9	11	14	14	17,2
E	-	19	22	24,5	27	30,5	37,5	46	55	69
G	M5	M5	M5	G1/8	G1/8	G1/8	G1/8	G1/8	G1/4	G1/4
H+	27	32*	32*	38,5*	39,5*	39,5*	39,5*	42*	46*	56*
H3	5,5	8	8	10,5	11,5	11	11,5	11	14	16
I1	15,5	-	-	-	36	42	50	62	82	103
I2	-	18	20	26	32	42	50	62	82	103
I3	-	12	15	15,5	-	-	-	-	-	-
I5	-	20	25,5	28	34	40	50	60	77	94
I6	-	10	12,7	14	-	-	-	-	-	-
K	5	6	8	8	10	10	13	13	17	22
L	3,5	4,6	5,7	5,7	5,7	5,7	6,8	8,8	9	11
L1	-	3,5	5,7	5,7	-	-	-	-	-	-
N	-	32	38,5	42	48	55	65	80	100	124
P	7	11	12	12	15	15	17	17	17	22
W	3,5	4,5	4,5	5,5	5,5	6,5	7,5	6,5	8	10

Famille de produit	Vérin compact (faible course)		
Série	F	Version	FISS / FISS...M

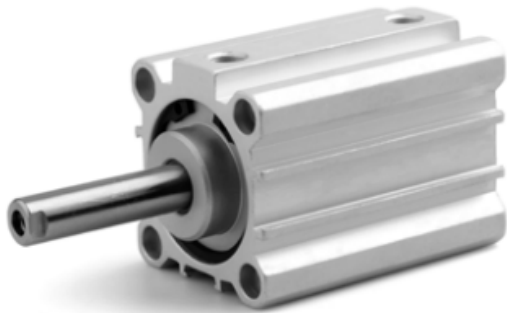

FISS

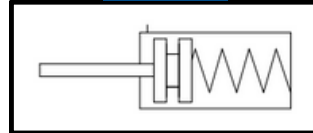

FISS...M

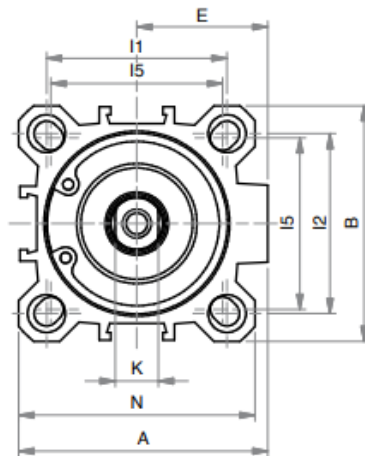
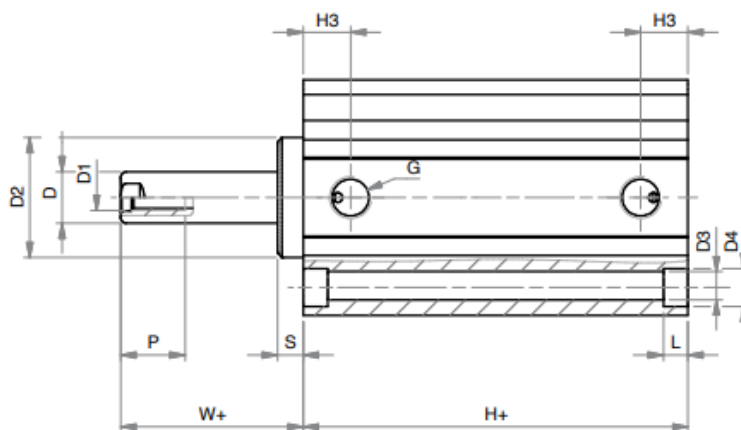
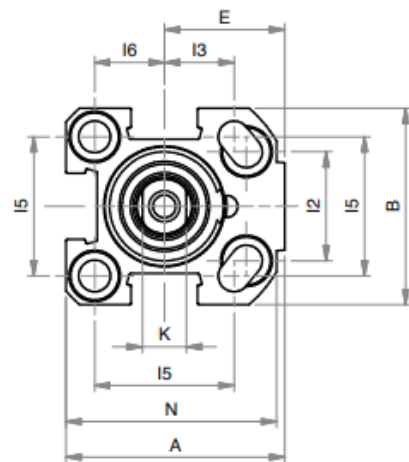
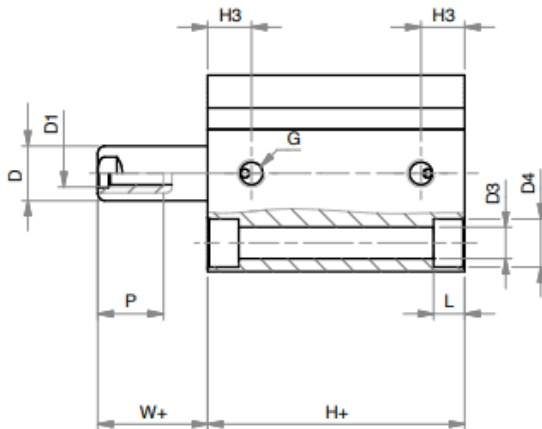
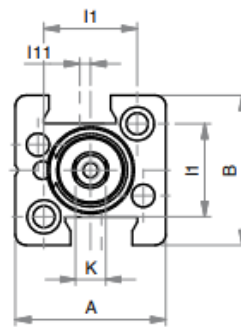
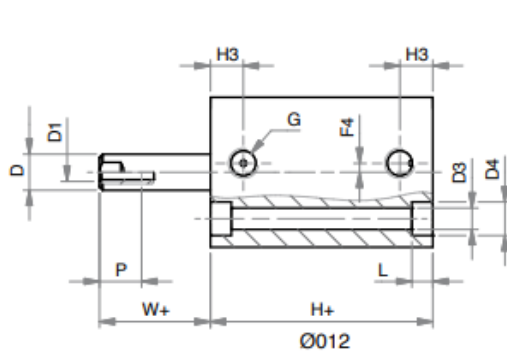
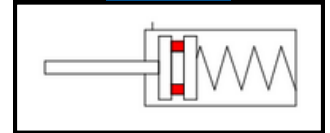

Ø032 - Ø040 - Ø050 - Ø063 - Ø080 - Ø100

Famille de produit	Vérin compact (faible course)		
Série	F	Version	FISS / FISS...M

Dimensions

	012	016	020	025	032	040	050	063
A	25	34	40	44,5	51	58	70	89
B	25	30	36	40	46	55	65	80
ø D	6	8	10	10	12	12	16	16
D1	M3	M4	M5	M5	M6	M6	M8	M8
ø D2	-	-	-	-	24,5	28	34	38,5
ø D3	3,7	**	5,8	5,8	5,8	5,8	6,8	9
ø D4	5,6	**	9	9	9	9	11	14
E	-	19	22	24,5	27	30,5	37,5	46
G	M5	M5	M5	G1/8	G1/8	G1/8	G1/8	G1/8
H+	***	32*	32*	38,5*	39,5*	39,5	39,5	42
H3	5,5	8	8	10,5	11,5	11	11,5	11
I1	15,5	-	-	-	36	42	50	62
I2	-	18	20	26	32	42	50	62
I3	-	12	15	15,5	-	-	-	-
I5	-	20	25,5	28	34	40	50	60
I6	-	10	12,7	14	-	-	-	-
K	5	6	8	8	10	10	13	13
L	3,5	4,6	5,7	5,7	5,7	5,7	6,8	8,8
L1	-	3,5	5,7	5,7	-	-	-	-
N	-	32	38,5	42	48	55	65	80
P	7	11	12	12	15	15	17	17
S	-	-	-	-	5	6	6	8
W+	3,5	4,5	4,5	5,5	11	12,5	13,5	15

Famille de produit	Vérin compact (faible course)		
Série	F	Version	FID

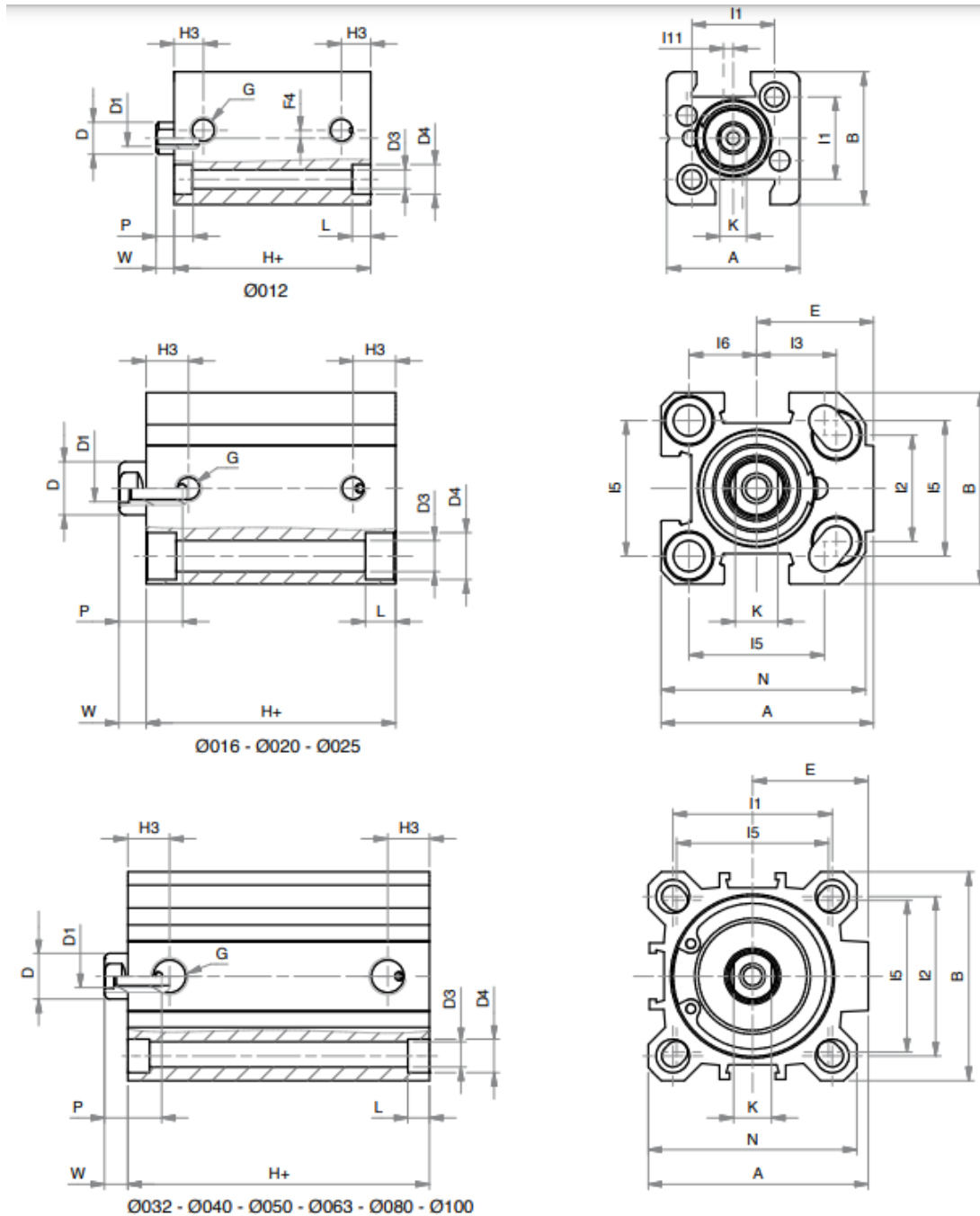
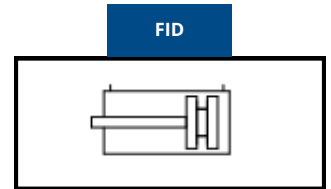
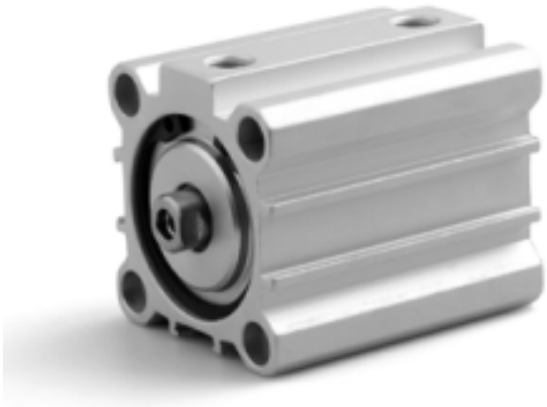

Famille de produit	Vérin compact (faible course)		
Série	F	Version	FID

Dimensions

ø	012	016	020	025	032	040	050	063	080	100
A	25	34	40	44,5	51	58	70	89	105	131
B	25	30	36	40	46	55	65	80	100	124
øD	6	8	10	10	12	12	16	16	20	25
D1	M3	M4	M5	M5	M6	M6	M8	M8	M10	M12
øD3	3,7	**	5,8	5,8	5,8	5,8	6,8	9	9	11
øD4	5,6	**	9	9	9	9	11	14	14	17,2
E	-	19	22	24,5	27	30,5	37,5	46	55	69
G	M5	M5	M5	G1/8	G1/8	G1/8	G1/8	G1/8	G1/4	G1/4
H+	17	27*	27*	28,5*	29,5	29,5	34,5	37	46	56
H3	5,5	8	8	10,5	11,5	11	11,5	11	14	16
I1	15,5	-	-	-	36	42	50	62	82	103
I2	-	18	20	26	32	42	50	62	82	103
I3	-	12	15	15,5	-	-	-	-	-	-
I5	-	20	25,5	28	34	40	50	60	77	94
I6	-	10	12,7	14	-	-	-	-	-	-
K	5	6	8	8	10	10	13	13	17	22
L	3,5	4,6	5,7	5,7	5,7	5,7	6,8	8,8	9	11
L1	-	3,5	5,7	5,7	-	-	-	-	-	-
N	-	32	38,5	42	48	55	65	80	100	124
P	7	11	12	12	15	15	17	17	17	22
W	3,5	4,5	5	5,5	6	6	7,5	7	8	10

Famille de produit	Vérin compact (faible course)		
Série	F	Version	FID...M

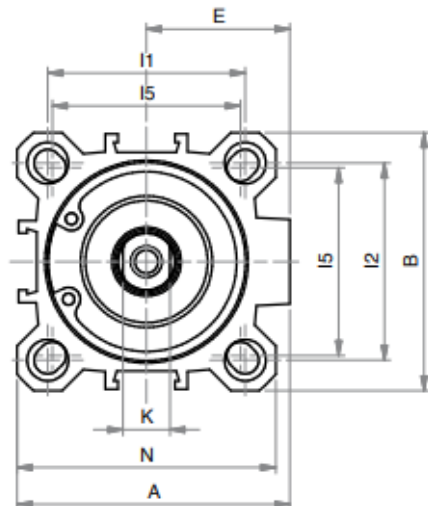
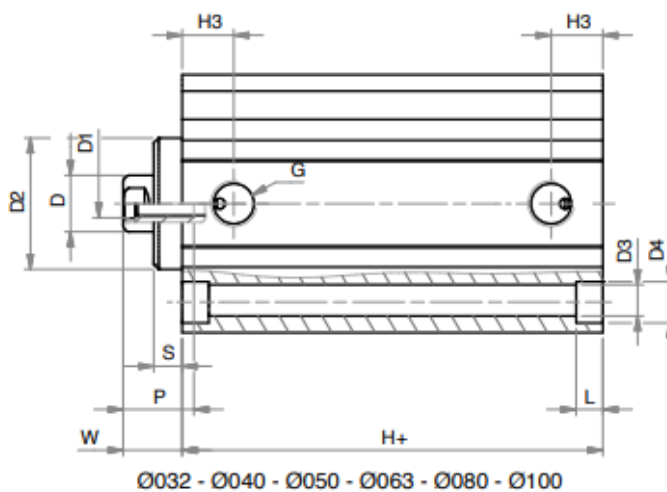
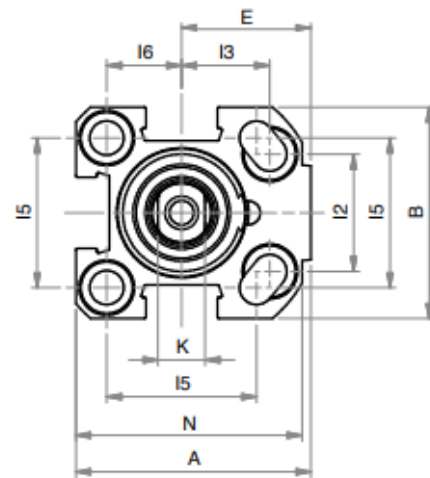
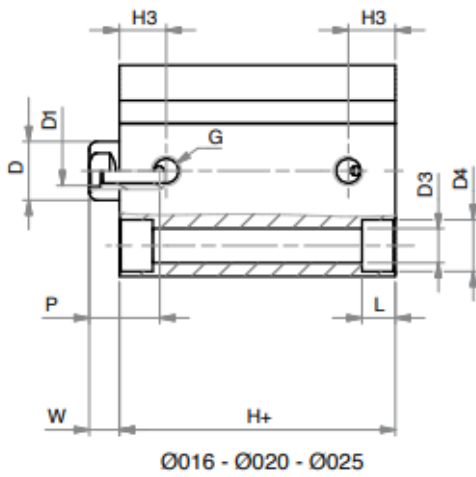
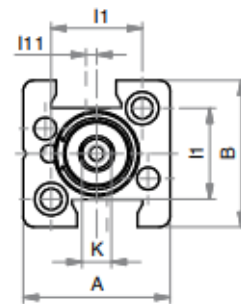
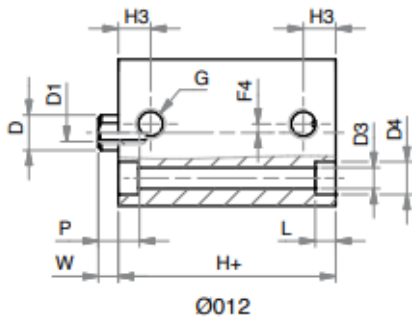
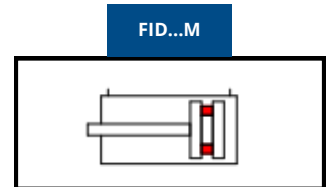

Famille de produit	Vérin compact (faible course)		
Série	F	Version	FID...M

Dimensions

ø	012	016	020	025	032	040	050	063	080	100
A	25	34	40	44,5	51	58	70	89	105	131
B	25	30	36	40	46	55	65	80	100	124
ø D	6	8	10	10	12	12	16	16	20	25
D1	M3	M4	M5	M5	M6	M6	M8	M8	M10	M12
ø D2	-	-	-	-	24,5	28	34	38,5	44	56
ø D3	3,7	**	5,8	5,8	5,8	5,8	6,8	9	9	11
ø D4	5,6	**	9	9	9	9	11	14	14	17,2
E	-	19	22	24,5	27	30,5	37,5	46	55	69
G	M5	M5	M5	G1/8	G1/8	G1/8	G1/8	G1/8	G1/4	G1/4
H+	27	32*	32*	38,5*	39,5	39,5	39,5	42	46	56
H3	5,5	8	8	10,5	11,5	11	11,5	11	14	16
I1	15,5	-	-	-	36	42	50	62	82	103
I2	-	18	20	26	32	42	50	62	82	103
I3	-	12	15	15,5	-	-	-	-	-	-
I5	-	20	25,5	28	34	40	50	60	77	94
I6	-	10	12,7	14	-	-	-	-	-	-
K	5	6	8	8	10	10	13	13	17	22
L	3,5	4,6	5,7	5,7	5,7	5,7	6,8	8,8	9	11
L1	-	3,5	5,7	5,7	-	-	-	-	-	-
N	-	32	38,5	42	48	55	65	80	100	124
P	7	11	12	12	15	15	17	17	17	22
S	-	-	-	-	5	6	6	8	10	10,5
W	3,5	4,5	4,5	5,5	11	12,5	13,5	15	18	20,5

Famille de produit	Vérin compact (faible course)		
Série	F	Version	FIDA / FIDA...M

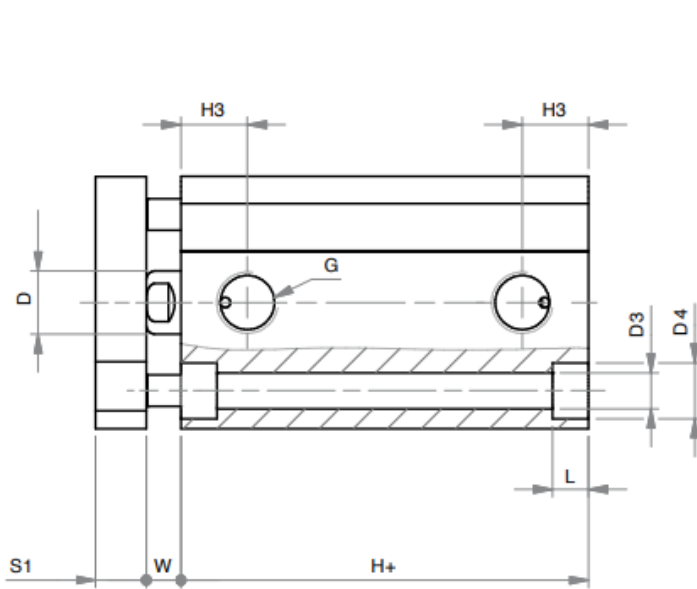
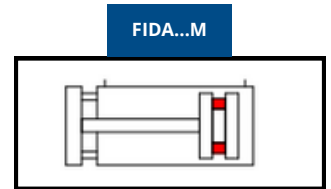
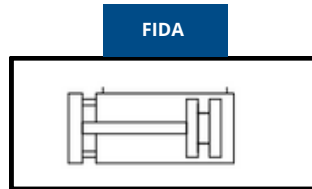

Ø020 - Ø025

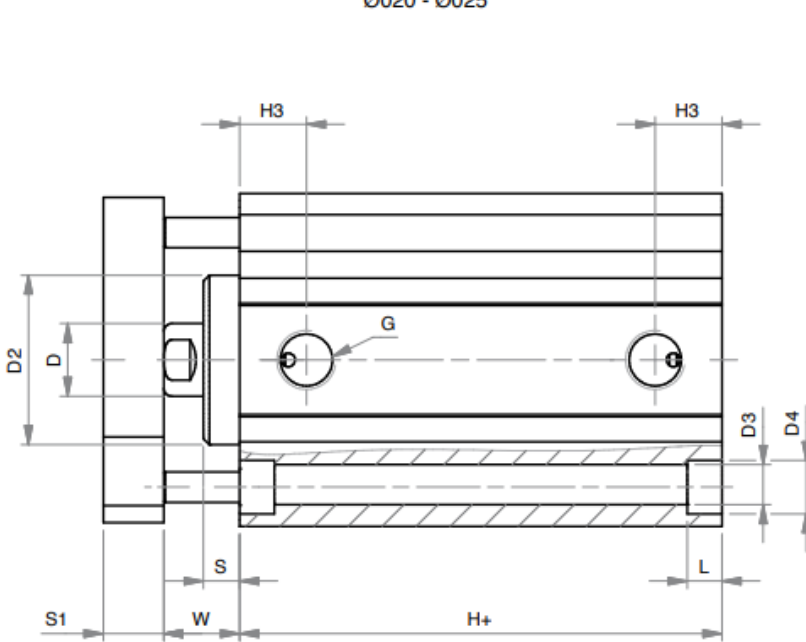
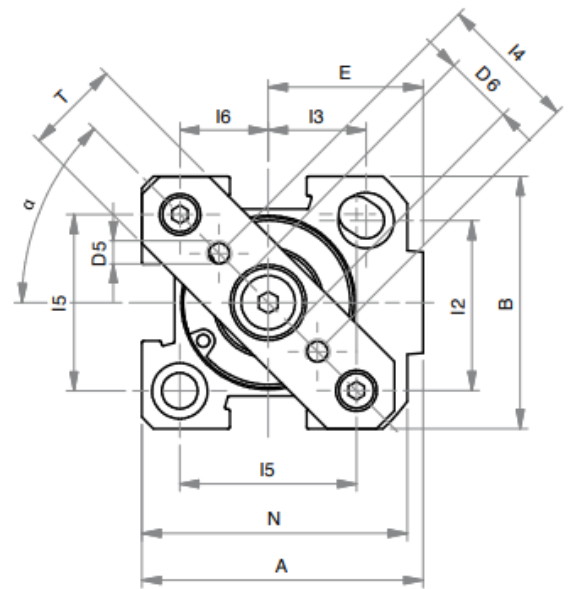

Ø032 - Ø040 - Ø050 - Ø063 - Ø080 - Ø100

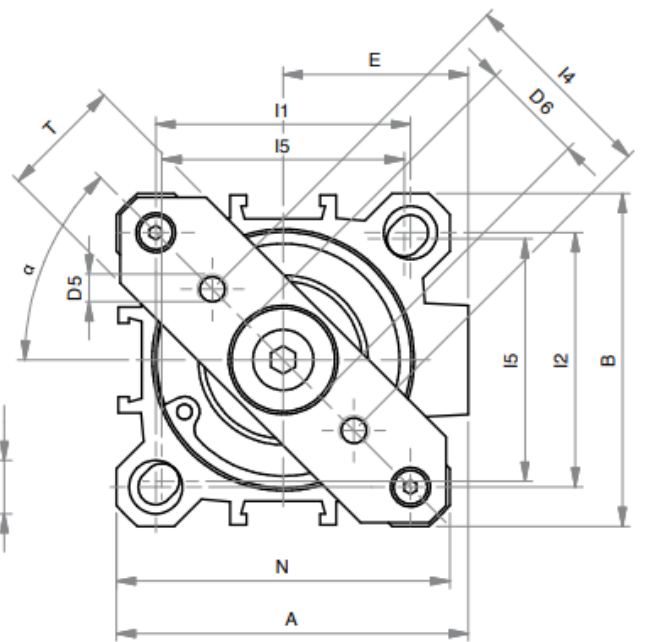

Famille de produit	Vérin compact (faible course)		
Série	F	Version	FIDA / FIDA...M

Dimensions

	020	025	032	040	050	063	080	100
A	40	44,5	51	58	70	89	105	131
B	36	40	46	55	65	80	100	124
α	45°	45°	41,5°	45°	45°	45°	45°	45°
ø D	10	10	12	12	16	16	20	25
ø D2	-	-	24,5	28	34	38,5	44	56
ø D3	5,8	5,8	5,8	5,8	6,8	9	9	11
ø D4	9	9	9	9	11	14	14	17,2
D5	M4	M4	M5	M5	M6	M6	M8	M10
ø D6	11	11	17	17	22	22	28	30
E	22	24,5	27	30,5	37,5	46	55	69
G	M5	G1/8	G1/8	G1/8	G1/8	G1/8	G1/4	G1/4
H+	32*	38,5*	39,5	39,5	39,5	42	46	56
H3	8	10,5	11,5	11	11,5	11	14	16
I1	-	-	36	42	50	62	82	103
I2	20	26	32	42	50	62	82	103
I3	15	15,5	-	-	-	-	-	-
I4	20	22	28	33	42	50	65	80
I5	25,5	28	34	40	50	60	77	94
I6	12,7	14	-	-	-	-	-	-
K	8	8	10	10	13	13	17	22
L	5,7	5,7	5,7	5,7	6,8	8,8	9	11
L1	5,7	5,7	-	-	-	-	-	-
N	38,5	42	48	55	65	80	100	124
S	-	-	5	6	6	8	10	10,5
S1	8	8	10	10	12	12	14	14
T	15	15	20	20	30	30	50	50
W	4,5	5,5	11	12,5	13,5	15	18	20,5

Famille de produit	Vérin compact (faible course)		
Série	F	Version	FIDP / FIDP...M

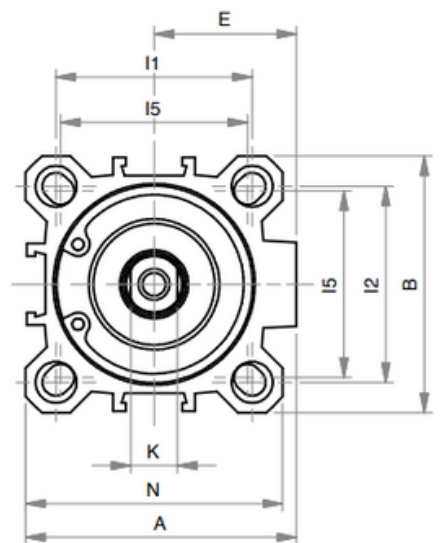
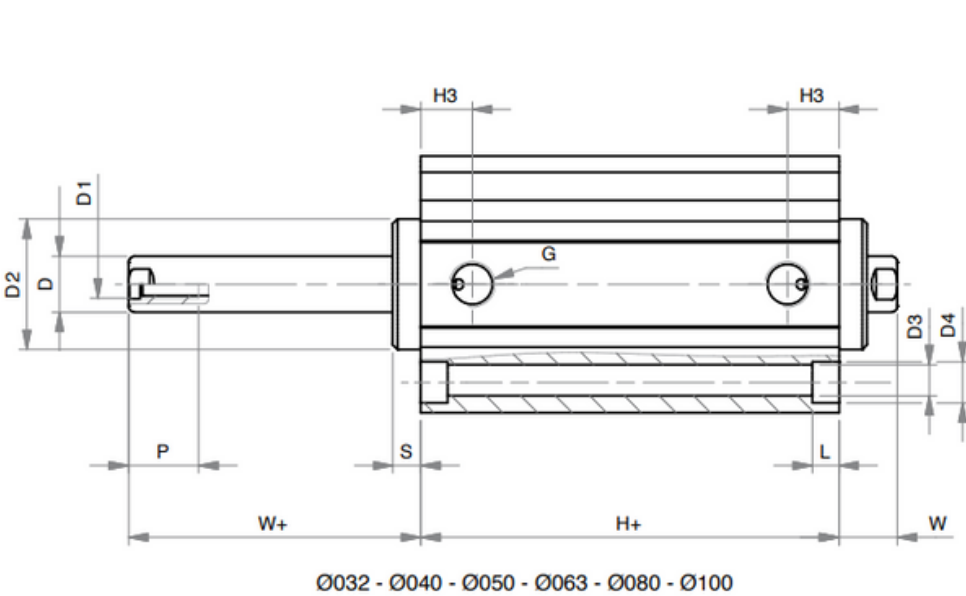
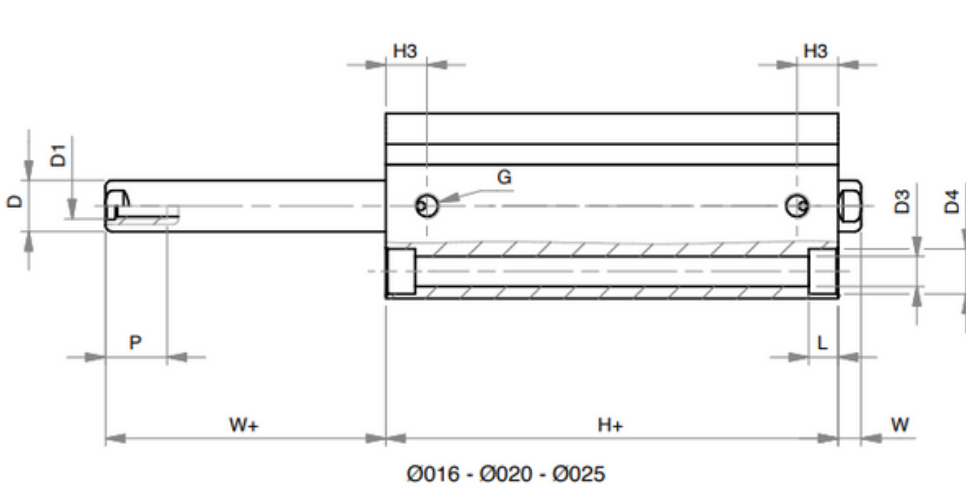
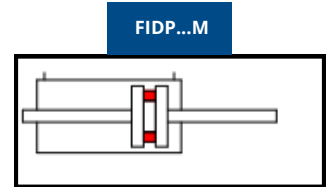
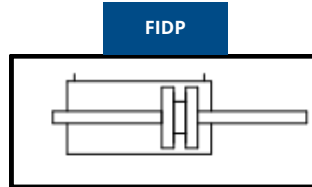
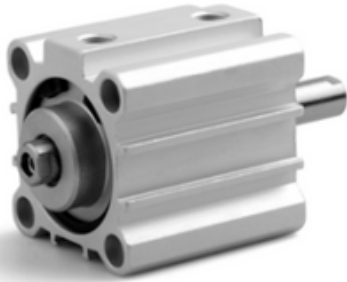

Famille de produit	Vérin compact (faible course)		
Série	F	Version	FIDP / FIDP...M

Dimensions

	016	020	025	032	040	050	063	080	100
A	34	40	44,5	51	58	70	89	105	131
B	30	36	40	46	55	65	80	100	124
ø D	8	10	10	12	12	16	16	20	25
D1	M4	M5	M5	M6	M6	M8	M8	M10	M12
ø D2	-	-	-	24,5	28	34	38,5	44	56
ø D3	**	5,8	5,8	5,8	5,8	6,8	9	9	11
ø D4	**	9	9	9	9	11	14	14	17,2
E	19	22	24,5	27	30,5	37,5	46	55	69
G	M5	M5	G1/8	G1/8	G1/8	G1/8	G1/8	G1/4	G1/4
H+	32*	32*	38,5*	39,5	39,5	39,5	42	46	56
H3	8	8	10,5	11,5	11	11,5	11	14	16
I1	-	-	-	36	42	50	62	82	103
I2	18	20	26	32	42	50	62	82	103
I3	12	15	15,5	-	-	-	-	-	-
I5	20	25,5	28	34	40	50	60	77	94
I6	10	12,7	14	-	-	-	-	-	-
K	6	8	8	10	10	13	13	17	22
L	4,6	5,7	5,7	5,7	5,7	6,8	8,8	9	11
L1	3,5	5,7	5,7	-	-	-	-	-	-
N	32	38,5	42	48	55	65	80	100	124
P	11	12	12	15	15	17	17	17	22
S	-	-	-	5	6	6	8	10	10,5
W	4,5	4,5	5,5	11	12,5	13,5	15	18	20,5
W+	4,5	4,5	5,5	11	12,5	13,5	15	18	20,5

Famille de produit	Vérin compact (faible course)		
Série	F	Version	FIDPA / FIDPA...M

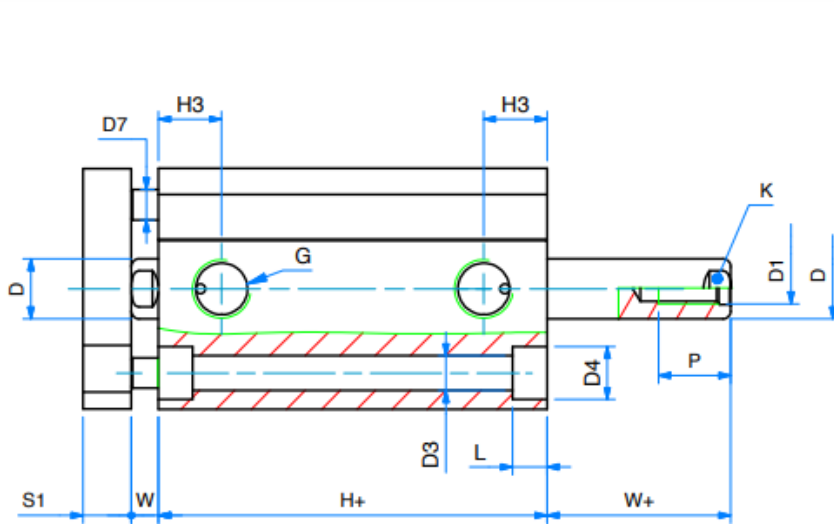
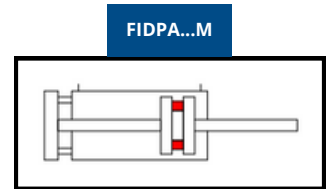
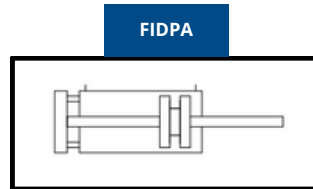
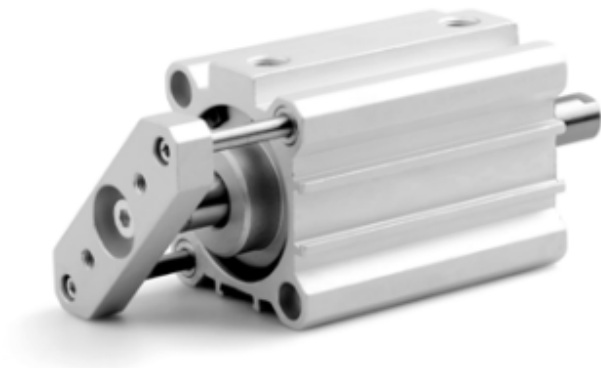

Ø016 - Ø020 - Ø025

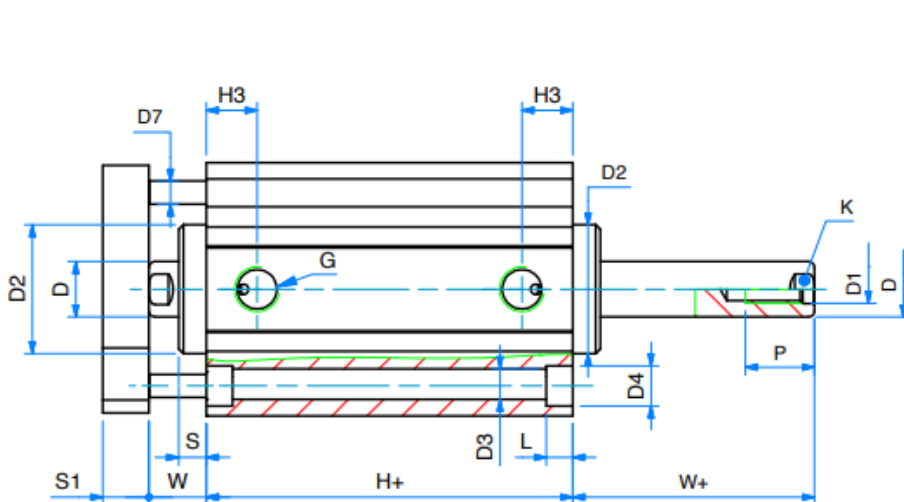
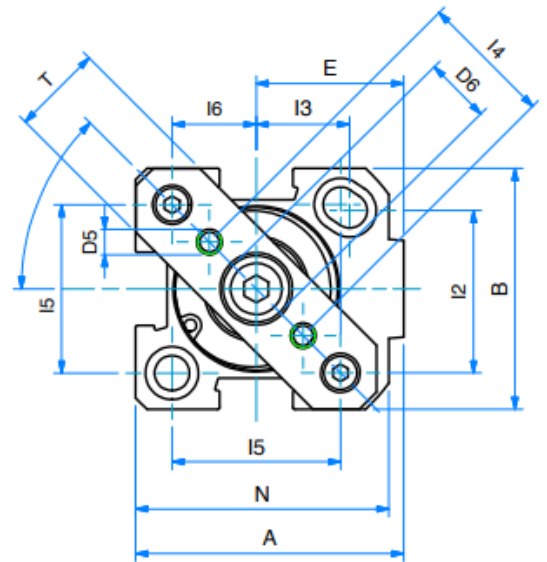

Ø032 - Ø040 - Ø050 - Ø063 - Ø080 - Ø100

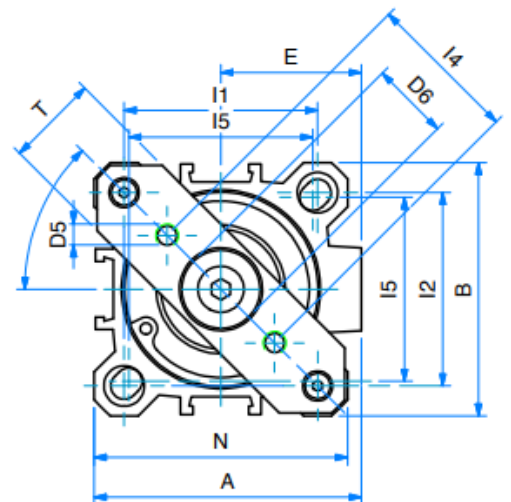

Famille de produit	Vérin compact (faible course)		
Série	F	Version	FIDPA / FIDPA...M

Dimensions

	020	025	032	040	050	063	080	100
A	40	44,5	51	58	70	89	105	131
B	36	40	46	55	65	80	100	124
α	45°	45°	41,5°	45°	45°	45°	45°	45°
ø D	10	10	12	12	16	16	20	25
D1	M5	M5	M6	M6	M8	M8	M10	M12
ø D2	-	-	24,5	28	34	38,5	44	56
ø D3	5,8	5,8	5,8	5,8	6,8	9	9	11
ø D4	9	9	9	9	11	14	14	17,2
D5	M4	M4	M5	M5	M6	M6	M8	M10
ø D6	11	11	17	17	22	22	28	30
E	22	24,5	27	30,5	37,5	46	55	69
G	M5	G1/8	G1/8	G1/8	G1/8	G1/8	G1/4	G1/4
H+	32*	38,5*	39,5	39,5	39,5	42	46	56
H3	8	10,5	11,5	11	11,5	11	14	16
I1	-	-	36	42	50	62	82	103
I2	20	26	32	42	50	62	82	103
I3	15	15,5	-	-	-	-	-	-
I4	20	22	28	33	42	50	65	80
I5	25,5	28	34	40	50	60	77	94
I6	12,7	14	-	-	-	-	-	-
K	8	8	10	10	13	13	17	22
L	5,7	5,7	5,7	5,7	6,8	8,8	9	11
L1	5,7	5,7	-	-	-	-	-	-
N	38,5	42	48	55	65	80	100	124
P	12	12	15	15	17	17	17	22
L	5,7	5,7	5,7	5,7	6,8	8,8	9	11
S	-	-	5	6	6	8	10	10,5
S1	8	8	10	10	12	12	14	14
T	15	15	20	20	30	30	50	50
W	4,5	5,5	11	12,5	13,5	15	18	20,5
W+	4,5	5,5	11	12,5	13,5	15	18	20,5